



# COMBITRAILER CT-521-S



 Technische gegevens	 Technische Daten	 Technical data	CT-521-S	CT-F22-S	CT-R31-S
Geschikt voor	Geeignet für	Suitable for	20 ft 2x 20 ft 40 ft (HC)	20 ft	20 ft
Schoteldruk	Sattellast	Kingpin weight	17.000 kg	17.000 kg	17.000 kg
Max. aslast per as	Max. Achslast pro Achse	Max. Axleload / axle	9.000 kg	9.000 kg	9.000 kg
Tot. toegestane massa	Gesamt zulässige Masse	Gross trailer weight	53.000 kg	35.000 kg	44.000 kg
Leeggewicht	Leergewicht	Empty weight	8.200 kg	3.700 kg	4.500 kg
Nuttig laadvermogen	Nutzlast	Payload	44.800 kg	31.300 kg	39.500 kg
Schotelhoogte	Sattelhöhe	Fifthwheel height	1.110 mm	1.110 mm	1.110 mm
Chassishoogte	Chassishöhe	Chassis height	1.110 mm	1.110 mm	1.110 mm
Bandenmaat	Reifengröße	Tyresize	385/55 R22,5	385/55 R22,5	385/55 R22,5
Electr. Aansluitingen	Elektrische Anschlüsse	Electrical connectors	15 pin only	15 pin only	15 pin only
Stuuras (-sen) op as	Lenkachse (-n) auf Achse	Steeringaxle on axle	1,2,5	-*	3
Liftas (-sen) op as	Liftachse (-n) auf Achse	Liftaxle on axle	1,2,5	1	3
*Stuurassen geblokkeerd	Lenkachsen verriegelt	Steeringaxles locked			

**OPTIES / OPTIONEN / OPTIONS**

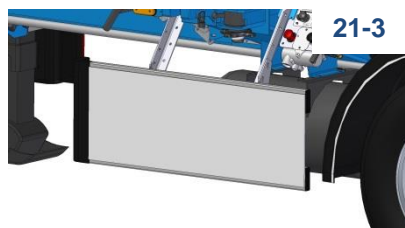
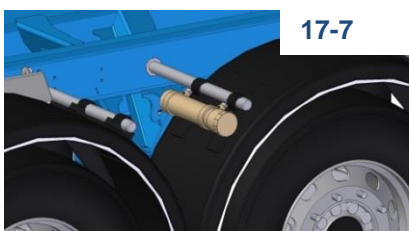
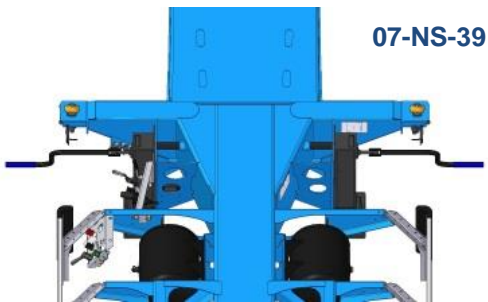
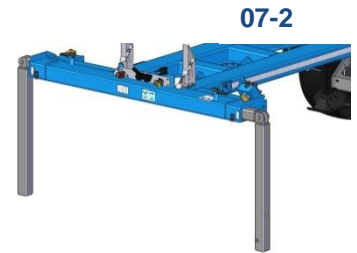
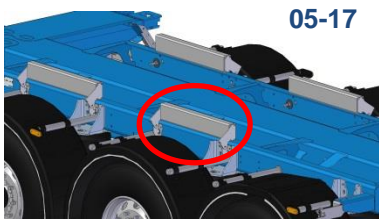

	 <b>Basis opties</b>	 <b>Basis Optionen</b>	 <b>Basic options</b>
11-4-15	Valx trommelremmen	Valx Trommelbremsen	Valx drumbrakes
19-B	Banden keus D-TEC	Reifen nach Wahl D-TEC	Tyremake D-TEC choice
	Standard 2-layer coating in RAL 3002,	RAL 5002, RAL 5010, RAL 5015, RAL 7016, RAL 7021, RAL 9005	
09-1-2	Schooperen bovenzijde	Spritzverzinken Oberseite	Schooping topside
17-21	Brede spatlap onder de bumper	Breiter Schmutzfänger	Mudflap under bumper
21-5	2 Wielkeggen op voor- en achterstuk	2 Radkeile auf Vorder- und Hinterteil	2 Wheelwedges on front- and rearpart
07-27	Douanestand	Zollstellung	Customs-position

	<b>Comfort opties</b>	<b>Komfort Optionen</b>	<b>Comfort options</b>
11-4-D1	Mercedes-Benz / SAF schijfremmen	Mercedes-Benz / SAF Scheiben	Mercedes-Benz / SAF discbrakes
11-CT-T1	D-TEC / BPW trommelremmen	D-TEC / BPW Trommelbremsen	D-TEC / BPW drumbrakes
	As 1 achterstuk handmatige liftas	Achse 1 Hinterteil manuelle Liftachse	Axle 1 rear part manual liftaxle
	Centrale smering	Zentralschmieranlage	Auto greasing system
13-9	Voeding EBS ook via remlichten	Strom EBS auch über Bremse	Power for EBS by brakelights too
11-3	2e rijhoogte	2. Fahrhöhe	2nd drive-height
19-55-01	Voorstuk op 385/55 ipv 385/65	Vorderteil auf 385/55 statt 385/65	Front part on 385/55 instead of 385/65
19-65	Bandenmaat 385/65R22,5.	Reifengröße 385/65 R22,5	Tyresize 385/65 R22,5
	Continental HTR2 / Goodyear LHT II	/ GT / Bridgestone	/ Michelin
	Alcoa DB	Alcoa DB	Alcoa DB
	Reservewiel (staal) met band	Reserverad Stahlfelge	Sparewheel (steel) with tyre
09-1-1	Schooperen volledig	Spritzverzinken völlig	Schooping full
09-6-SPECIAL	spuiten 2-laags 2K natlak naar keuze naven + doppen spuiten	Lackieren 2 Schicht 2K nach Wahl Naben und Kappen lackiert	2-Layer coating 2K customer choice Hubs and caps painted
15-12	6x ronde 3-kamer lampen, alles LED	6x Runde 3-Kammerleuchten LED	6 Round lights, LED
05-17	Klapkokers ivm geen tunnel	Klappstützen wegen ohne Tunnel	Filling pieces due to no tunnel
07-1	Kunststof gereedschapskist links.	Kunststoff Werkzeugkasten links	Plastic toolbox
07-2	Steunpoten in de kopbalk	Stützen im Frontbalken	Legs in frontbeam
07-3	Kingpenslothouder 2x	Halter für Königszapfenverriegelung 2x	Holder for kingpinlock 2x
07-5	Gevaarlijke stoffen bord	Gefahrgutschild	ADR sign at the rear, orange
07-NS-39	Jost Modul met 2 slingers achterstuk	Jost Modul mit 2 Kurbel am Hinterteil	Jost Modul with 2 cranks on rearpart
07-NS-9	Reclameplaat (alleen op achterstuk)	Werbungstafel Stahl (nur am Heckteil)	Steel plate (only at rear part)
17-19	Reservewiel drager	Reserveradträger	Sparewheelcarrier
17-7	Documenten koker uit plastic.	Dokubox Kunststoff	Document tube
21-3	Zijbeplating witte trespa	Seitl. Unterfahrschutz Trespa, weiß	Trespa sidefenders, white
21-8	Kingpinslot	Königszapfenverriegelung	Kingpinlock
03-4-A	ADR-fabrikantverklaring	ADR Herstellerbestätigung	ADR Manufacturer certificate
25-NS-2	LZV uitgevoerd en gekeurd	nur für NL	NL only
17-2	ADR/VLG uitvoering incl certificaten	nur für NL	NL only

