

PORTMASTER PM-3-S



Technische gegevens

Geschikt voor

Schoteldruk
 Maximale aslast per as
 Totaal toegestane massa
 Leeggewicht
 Nuttig laadvermogen
 Schotelhoogte
 Chassishoogte
 Bandenmaat
 Elektrische aansluitingen



Technische Daten

Geeignet für

Sattellast
 Max. Achslast per Achse
 Gesamt zulässige Masse
 Leergewicht
 Nutzlast
 Sattelhöhe
 Chassishöhe
 Reifengröße
 Elektrische Anschlüsse



Technical data

Suitable for

Kingpin weight
 Maximal Axleload / axle
 Gross trailer weight
 Empty weight
 Payload
 Fifthwheel height
 Chassisheight
 Tyresize
 Electrical connectors

PM-3-S

20 ft rear
 20 ft central
 20 ft tank
 30 ft
 2x 20 ft
 40 ft (HC)
 16.000 kg
 9.000 kg
 43.000 kg
 4.500 kg
 38.400 kg
 1.110 mm
 1.110 mm
 385/55 R22,5
 2x 7-pin + + 1x 15 pin

OPTIES / OPTIONEN / OPTIONS

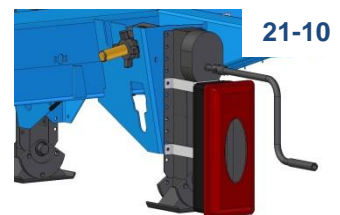
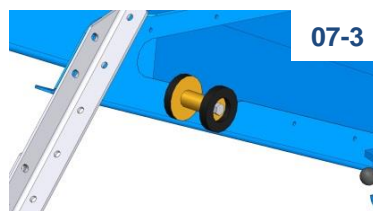
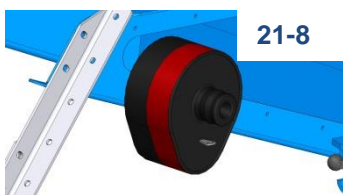
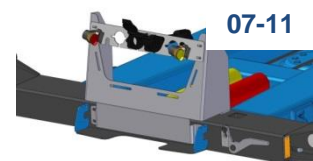
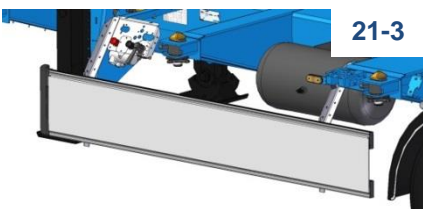
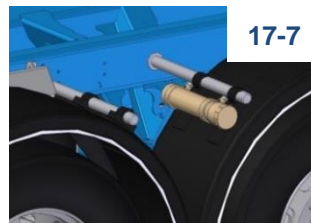
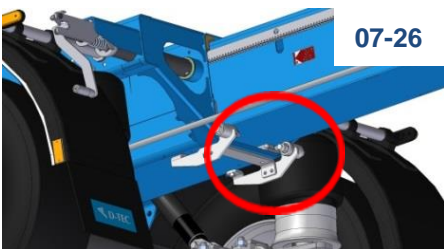
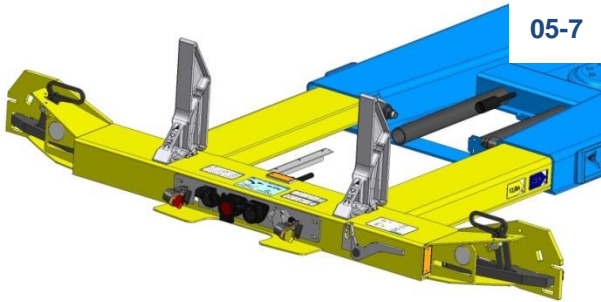

		
Basis opties	Basis Optionen	Basic options
11-4-15	Valx trommelremmen	Valx drumbrakes
	As 1 liftas manueel / automatisch	Axle 1 liftaxle manual / automatic
19-55	Bandenmaat 385/55R22,5	Tyresize 385/55 R22,5
19-B	Banden keus D-TEC	Tyremake D-TEC choice
	1 laag 2K natlak RAL 5015 / 9005	1-Layer coating 2K RAL 5015 / 9005
09-1-2	Bovenzijde schooperen	Topside schooping
05-7	Flexilock voor 45' legaal	Flexilock for 45' legal
21-5	2 Wielkeggen	2 Wheelwedges
21-16	Containerstops	Containerstops
05-4-1	Geen 20' centraal stand	Without 20' central position
Comfort opties	Komfort Optionen	Comfort options
	VALX / Mercedes-Benz / SAF schijf	VALX / Mercedes-Benz / SAF disc
11-4-8	BPW trommelremmen	BPW drumbrakes
11-2-17	laatste as naloop gestuurd	Last axle steeringaxle
	As 1 aut. / handm. liftas, as 3 handm.	A. 1 aut./man. liftaxle, axle 3 manual
19-65	Bandenmaat 385/65R22,5.	Tyresize 385/65 R22,5
	Continental HTR2 /	Michelin XTE3
19-7-3	Alcoa Durabright 6 alu velgen	Alcoa Durabright 6 alloy rims
09-1-1	Volledig schooperen	Full schooping
	Standard Coating in RAL 3002,	RAL 7016, RAL 7021, RAL 9005
09-6-SP	spuiten 2-laags 2K natlak naar keuze	2-Layer coating 2K customer choice
09-4-3	naven + doppen spuiten	Hubs and caps painted
15-12	6x ronde 3-kamer lampen, alles LED	6 Round lights, LED
15-NS-14	4x ronde 3-kamer lampen, bol	4 Round lights, bulbs
07-11	Verhoogde stekkerplaat	Higher connectors at the front
07-26	Rolletjes onder achterkoker	Bearings for easier cranking out
07-3	Kingpenslohouder	Holder for kingpinlock
07-5	Gevaarlijke stoffen bord	ADR sign at the rear, orange
07-NS-9	Reclameplaat	Steel plate at the rear, painted
17-7	Documenten koker uit plastic.	Document tube
17-21	Brede spatlap onder de bumper	Mudflap under bumper
21-10	Houder zonder 6 kg brandblusser	Holder without 6kg fire extinguisher
21-3	Zijbeplating witte trespa	Trespa sidefenders, white
21-8	Kingpinslot	Kingpinlock
03-4-A	ADR-fabrikantverklaring	ADR Manufacturer certificate
25-NS-2	LZV uitgevoerd en gekeurd	only NL
17-2	ADR/VLG uitvoering incl certificaat	only NL

